

## 360-80 Intelligent Channel Bank Shelf

CONTENTS	PAGE
Part 1. GENERAL .....	2
Part 2. SITE REQUIREMENTS .....	2
Part 3. INSPECTION .....	3
Part 4. SHELF INSTALLATION .....	3
Part 5. POWER CONNECTIONS .....	6
Part 6. SIGNAL CABLING .....	7
Part 7. CHANNEL UNIT INSTALLATION & POWER UP .....	8
Part 8. TECHNICAL ASSISTANCE .....	8
Part 9. WARRANTY & CUSTOMER SERVICE .....	9
Part 10. SPECIFICATIONS .....	10

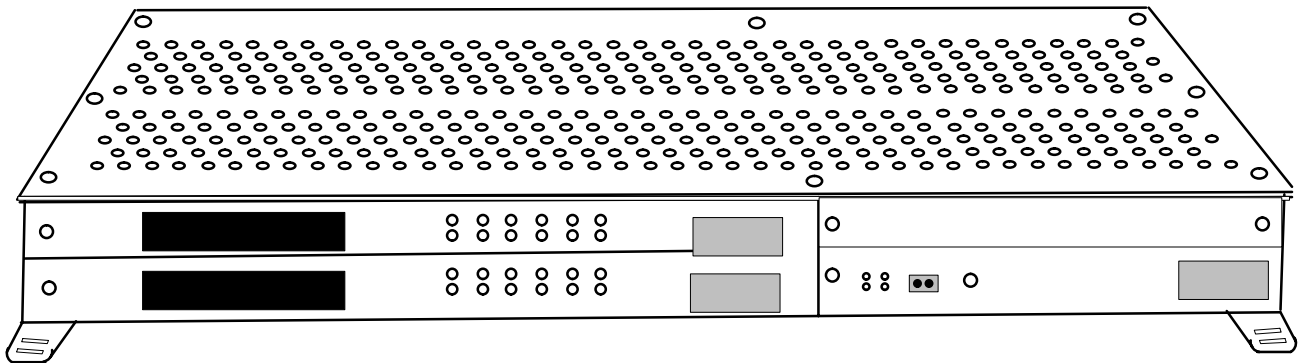

Figure 1. 360-80 Shelf

## 1. GENERAL

### 1.1 Document Purpose

This document provides general and installation information for the 360-80 shelf, shown in Figure 1. This document covers the following part numbers:

Part Number	Description
93-036080	Intelligent Channel Bank
98-036080	Intelligent Channel Bank with UL kit

### 1.2 Document Status

This document is reprinted to add product support information for E1.

### 1.3 Equipment Function

The 360-80 shelf is used as an Intelligent Channel Bank (ICB). A 360-80 shelf may be set up in one of the following ways:

- 1 T1 or E1 control unit and 1 to 3 multi-channel units.
- 1 T1 or E1 control unit, 1 secondary T1 or E1 unit, and 1 or 2 multi-channel units.
- 1 T1 or E1 control unit, 1 or 2 multi-channel units, and an HDSL or HDSL2 unit using a Charles Industries HDSL/HDSL2 200 series adaptor.

### 1.4 Equipment Location/Mounting

The 360-80 shelf is intended for installation in a variety of locations. It is not required that it be installed in a restricted access location or in a controlled environment. The shelf is UL approved.

## 2. SITE REQUIREMENTS

The 360-80 ICB shelf mounts in a standard 19- or 23-inch relay rack, occupying 1.75 inches of vertical rack space (1 rack mounting space). The shelf may also be wall mounted or placed on a smooth, flat surface. One shelf has positions for 1 control unit, 1 secondary unit and 1–3 multi-channel units. Each unit has connectors on the front and/or rear to allow connection to upstream or downstream services.

### 2.1 Power Requirements

The shelf is locally powered with –48 VDC battery and ground connections. Current draw depends on the type and number of units installed. Recommended fusing is 4 Amps. An optional external power supply allows operation with 110/220 VAC at 50/60 Hz.

### 2.2 Tool Requirements

The following tools are required for mounting the 360-80 shelf:

- A #2 Phillips head screwdriver for use on the mounting bracket and to secure the channel units in the shelf.
- A fastening tool for whatever rack fasteners are used.
- Wire cutting and stripping tools for power wiring.
- Test gear for checking voltages.

### 2.3 Rack Requirements

- A standard 19- or 23-inch relay rack (channel or unequal flange duct).
- Primary protection should be provided for any exposed lines.
- Power from a fused battery distribution panel.

- Earth/Frame Ground
- Sufficient space provided both in front of and behind the shelf to allow free access to the equipment.

## 2.4 Environmental Requirements

- A sheltered environment not exposed to direct moisture, with an ambient temperature within  $-40^{\circ}$  to  $+65^{\circ}$  C. Some of the channel units have limited temperature ranges—see the documentation for each individual unit for more information.
- It is recommended that one rack space of 1.75 inches just above the unit be left empty to allow proper ventilation and air flow. No more than half of the holes in the top cover should be blocked at any time.

## 3. INSPECTION

### 3.1 Inspect for Damages

Inspect the equipment thoroughly upon delivery. If the equipment has been damaged in transit, immediately report the extent of damage to the transportation company.

### 3.2 Equipment Identification

Charles Industries equipment is identified by a model and issue number imprinted on the equipment. Each time a major engineering design change is made on the equipment, the issue number is advanced by one number on any following models that are manufactured. Therefore, be sure to include both the model number and its issue number when making inquiries about the equipment.

## 4. SHELF INSTALLATION

After the site requirements have been verified, the shelf may be installed at the specified location.

### **CAUTION**

**The shelf should be empty during the shelf mounting procedures. If any units are in the shelf, remove and store them in accordance with static sensitive device storage procedures.**

### **CAUTION**

**Hazardous voltages may exist on the shelf. Always exercise caution when wiring a live circuit or when performing maintenance.**

### 4.1 Mounting the Brackets on the Shelf

The position and orientation of the shelf mounting brackets depends on the type of rack used for shelf mounting. The shelf may be front mounted in a standard channel bulb-angle or cable-duct rack (5-inch projection) or rear mounted in an unequal flange duct type rack. Therefore, depending on the orientation of the shelf the mounting brackets will be mounted in one of three possible positions (see Figure 2). The shelf is also shipped with rack mounting hardware including screws in both metric and standard sizes.

The mounting brackets can be rotated for use in wall mounting.

Optional adhesive feet may be attached to the bottom of the shelf so that it may be placed on a desk or other smooth surface.

To flush-mount from the front of a rack or cabinet, mount the brackets to the first set of mounting holes. To flush-mount from the rear of an unequal flange cable duct relay rack, use the second set of mounting holes. See Figure 3.

To mount with a 5-inch projection from the front of the rack or cabinet, use the second set of mounting holes. See Figure 4.

If the shelf mounting brackets are shipped loose or need to be reinstalled, use the following procedure.

Step	Action
1.	If necessary, remove the mounting brackets from the shelf. Save the screws for re-use. There should be 3 screws for each bracket.
2.	Position the brackets for the 19-inch or 23-inch relay rack (see Figure 2).
3.	Mount the brackets to the first or second set of mounting holes, depending on the required shelf orientation, using 3 screws for each bracket.

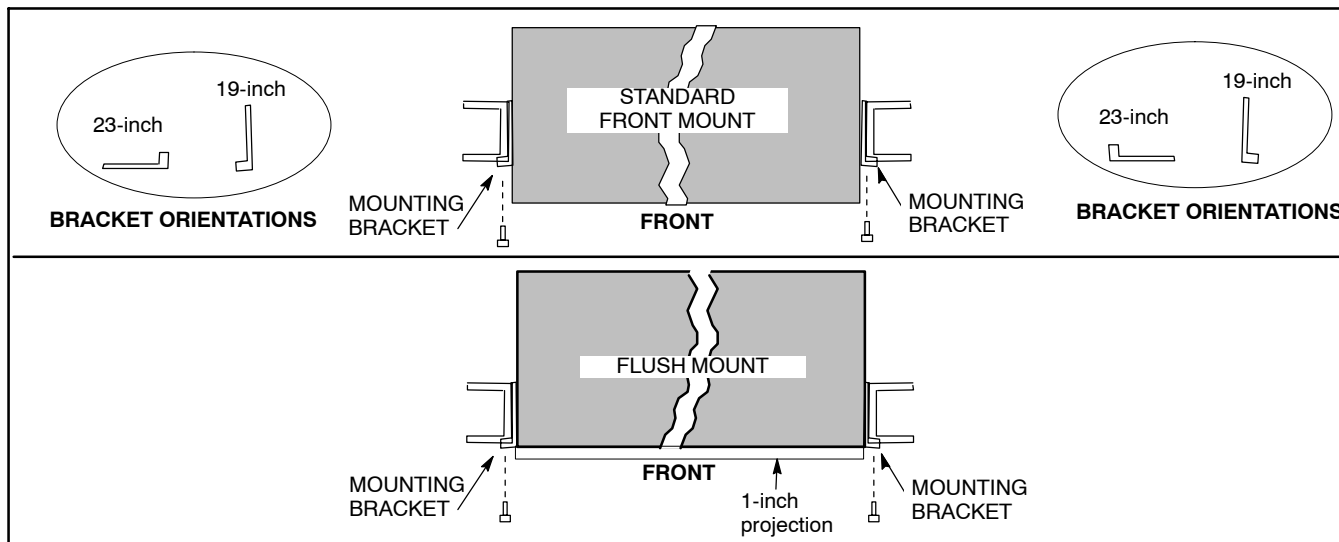

Figure 2. Mounting Bracket Orientation (Top View)

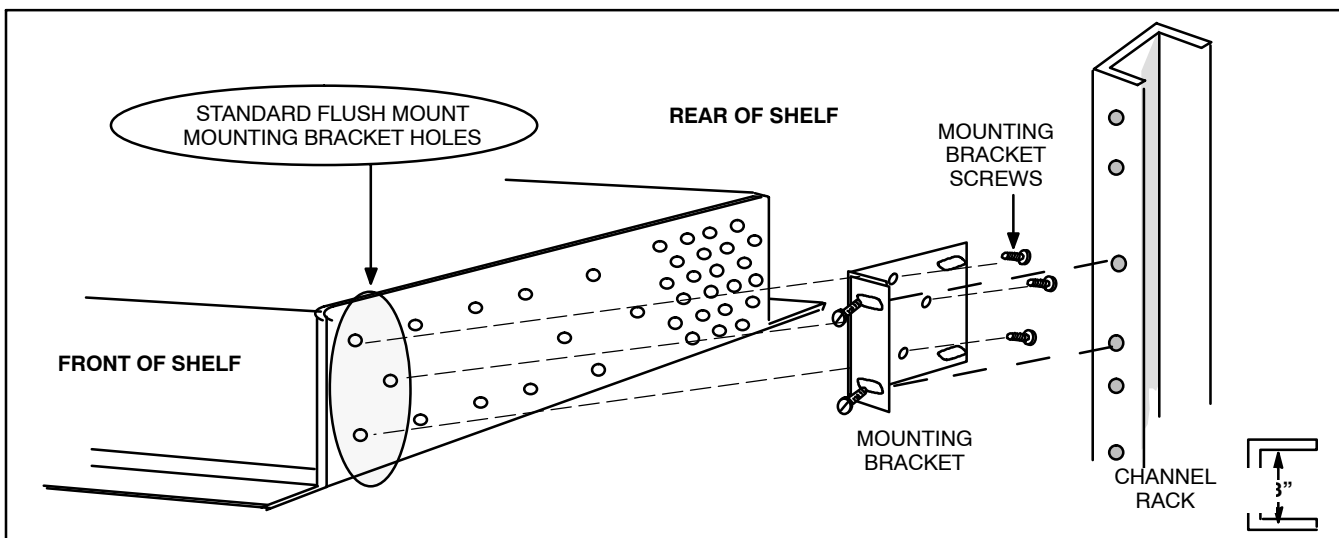
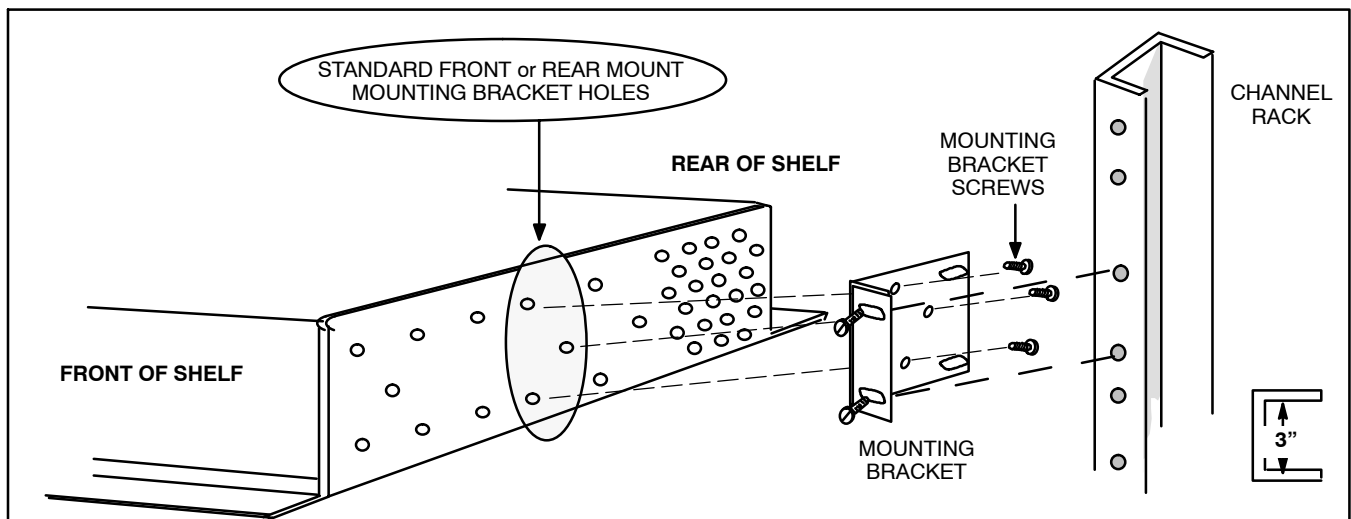

Figure 3. Shelf Mounting Bracket Position for Standard Flush Mount



**Figure 4. Shelf Mounting Bracket Position for Standard Front or Rear Mount**

#### 4.2 Wall Mounting

Vertical installation (walls, specially build structures, etc.) require strict adherence to the mounting instructions to assure trouble free operation and to protect the safety of personnel.

The shelf should be mounted at a height that will permit convenient access for performing maintenance.

The shelf will be mounted with one bracket above the other. The front of the shelf can face either to the right or the left. This will provide front panel access on one side of the shelf and rear panel access on the other side.

If the shelf cannot be mounted to a wall stud a plywood mounting board is required.

#### **CAUTION**

**If using a plywood mounting board, there should be at least two vertical support studs behind the board.**

A fully-equipped 360-80 weighs approximately 6 pounds. The unit should be mounted at a height that will permit convenient access for maintenance. Figure 5 shows the necessary clearances required when in operation.

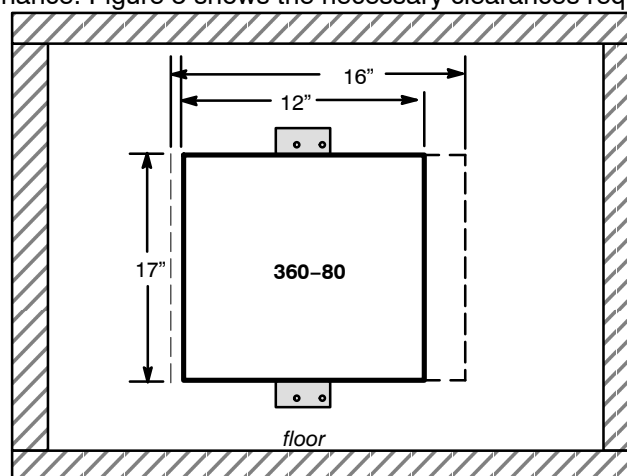

**Figure 5. Front View Clearance of the 360-80 ICB Shelf**

Step	Action
1.	Remove and rotate the bracket 90 degrees so that the flat of the bracket is toward the bottom of the shelf (see Figure 6).
2.	Mount the bracket to the shelf.

Step	Action
3.	Repeat steps 1 and 2 for the bracket on other side of the shelf.
4.	If mounting directly to a wall, locate a stud and mark a spot for the top bracket over the stud.
5.	Drill a pilot hole for the fastener at the marked spot (use whatever fasteners are appropriate per local practice).
6.	Mount the shelf using one of the fasteners through one of the brackets.
7.	Hold a level across the top of the shelf and level the unit.
8.	Mark the mounting surface for all the other holes to be used to mount both brackets.
9.	Drill pilot holes for the remaining fasteners at the marked spots.
10.	Install the remaining fasteners through the mounting brackets.
11.	Tighten the fasteners

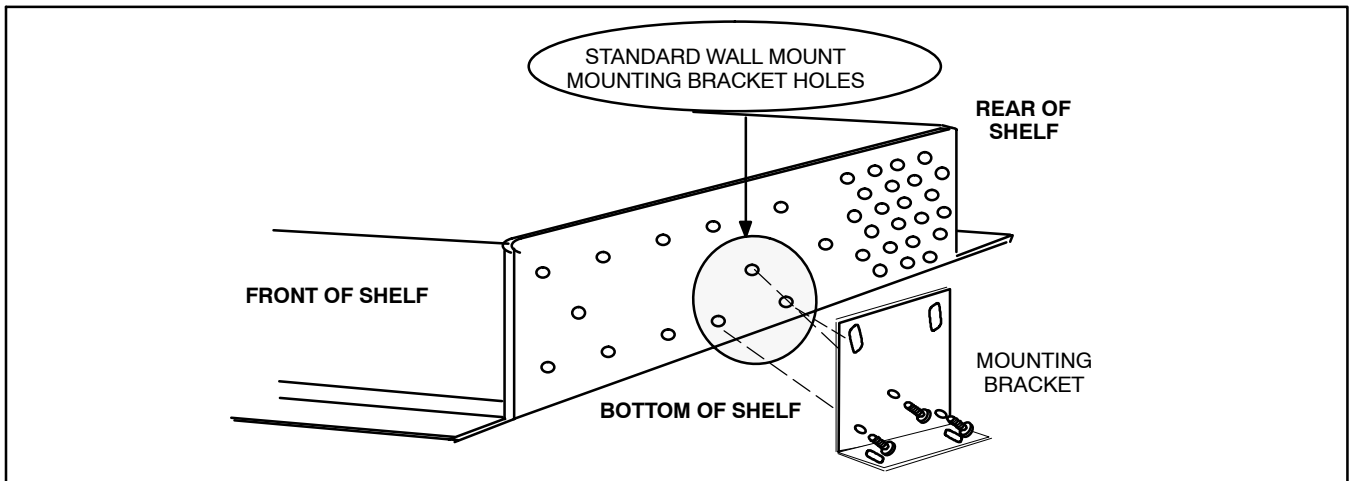

Figure 6. Shelf Mounting Bracket Position for Wall Mounting

#### 4.3 Desk Mounting

Step	Action
1.	Remove the shelf brackets.
2.	Attach adhesive rubber feet to the bottom of the shelf (supplied—shipped loose in the box).
3.	Place the shelf on a smooth flat surface and ensure that the shelf is stable.

### 5. POWER CONNECTIONS

The shelf is powered from a -48 volt DC output power supply. The shelf should be powered from a fused power distribution panel. Locate the shelf power terminal strip and connect the shelf power wiring as shown in Figure 7. 18 AWG stranded wire should be used for -48 V and ground.

**CAUTION**

**Ensure that all power to the shelf power source (power distribution panel, etc.) is turned off.**

Step	Action
1.	<b>Rear Panel Installation.</b> The T1/E1 controller's rear panel must be installed prior to making any power connections. Reference the T1/E1 Controller document for the correct installation procedure.
2.	<b>Frame Ground.</b> Obtain the appropriate gauge and length wire for the frame ground (#12 AWG is recommended). Connect one end to the FRAME GND ( $\perp$ ) terminal on the shelf. Connect the other end to office frame ground.
3.	<b>Power Ground.</b> Obtain the appropriate gauge and length wire for the power ground. Connect one end to the -48 VR terminal on the shelf terminal block (see Figure 7). Connect the other end to the power ground source (power distribution panel).
4.	<b>-48 VDC Battery.</b> Obtain the appropriate gauge and length wire for the -48 VDC battery. Connect one end to the BATT -48V terminal on the shelf terminal block (see Figure 7). Connect the other end to the CO -48 VDC battery source (power distribution panel).
5.	Replace the protective cover over the power connections.

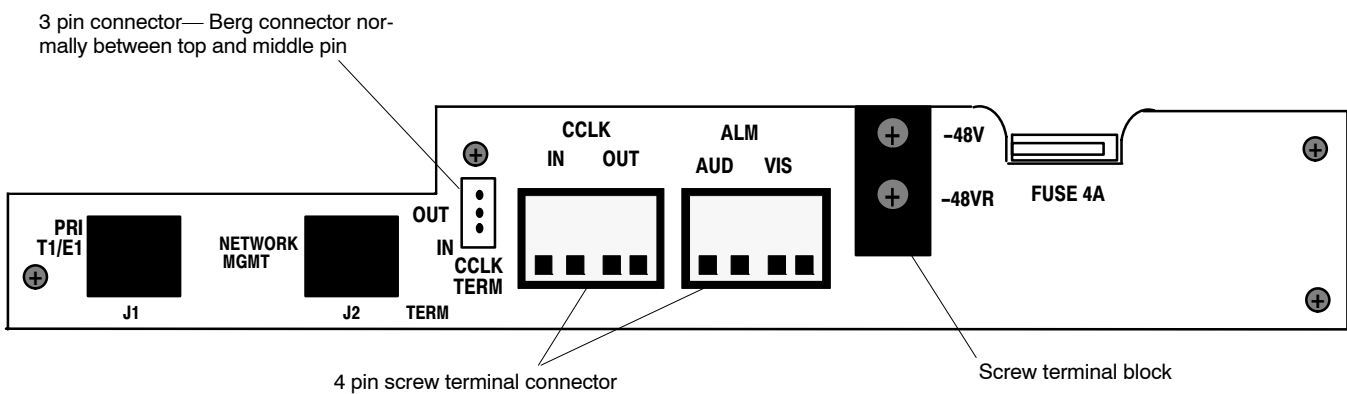

**Figure 7. Shelf Power Terminal Strip**

### 5.1 Redundant Powering

If redundant powering is required, order kit number 97-001786.

### 5.2 AC Powering

If powering from a standard 120 VAC outlet is required, order part number 93-855180.

## 6. SIGNAL CABLING

### 6.1 T1/E1 Controller Unit(s)

The shelf cabling for the controller unit(s) depends on the unit(s) used. See the T1 or E1 controller documentation for cabling information.

### 6.2 Multi-channel Units

The shelf cabling for the channel units depends on the units used. See channel unit documentation for cabling information.

### 6.3 Alarm Connections

The alarm connections are modularized to ease future wiring changes. The connector is a 4-lead connector. The typical connection is expected to be 18 or 22 AWG wire. When no alarm condition exists, the relay contacts will be open. Refer to Figure 7 for connections.

In an alarm condition, the audible and visual relay contact are closed. Pressing the ACO button will open the relay contacts for the audible alarm, causing the audible alarm to stop. This does NOT clear the alarm condition. The visual relay contacts will open when the alarm condition clears.

### 6.4 Composite Clock connections

The composite clock connections are modularized to ease future wiring changes. The connector is a 4-lead connector. Two of the leads are used to receive the composite clock signal into the ICB. The other two leads are to output the composite clock signal from the ICB. See Figure 7 for connections.

### 6.5 HDSL/HDSL2 Adaptor Kit (optional)

The HDSL/HDSL2 adaptor kit (97-001787) contains an adaptor for an HDSL or HDSL2 card, and a cable to connect the T1 signal to the T1 controller unit.

## 7. CHANNEL UNIT INSTALLATION & POWER UP

There are 2 types of channel units used in the shelf: the T1/E1 controller unit and the multi-channel units. One controller unit is necessary for each shelf.

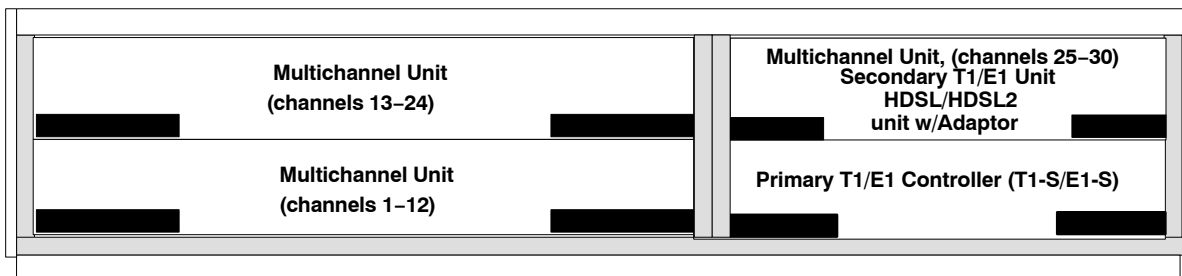

Figure 8. 360-80 ICB Common Equipment Configuration

### 7.1 Power-up the Shelf

Step	Action
1.	After installing the shelf, apply power to the fused power distribution panel feeding the shelf.
2.	Using a DC voltmeter, check for proper voltage (-42 to -56 VDC) across the -48 VR and -48V rear terminals.

### 7.2 Install/Test Channel Units

Power-up indications will depend on the individual unit. See the documentation for the unit you are installing.

**CAUTION**

**Installation and removal of channel units should be done with care. Do not force a unit into place. If excessive resistance is encountered while installing a unit, remove the unit and check the card guides and connector to verify proper alignment and the absence of foreign material.**

### 7.3 UL Installations

For UL compliant installations, install the blank panels provided in the UL kit (97-001793) to cover the front and the rear of slots where no card is installed.

## 8. TECHNICAL ASSISTANCE

If technical assistance is required, contact Charles Industries' Technical Services Center at:

847-806-8500  
 847-806-8556 (FAX)  
 800-607-8500  
 techserv@charlesindustries.com (e-mail)



## 9. WARRANTY & CUSTOMER SERVICE

### 9.1 Warranty

Charles Industries, Ltd. offers a 2-year warranty this product. Contact your local Sales Representative at the address or telephone numbers below for warranty details. The warranty provisions are subject to change without notice. The terms and conditions applicable to any specific sale of product shall be defined in the resulting sales contract.

Charles Industries, Ltd.  
5600 Apollo Drive  
Rolling Meadows, Illinois 60008-4049  
U.S.A.  
847-806-6300 (Main Office)  
847-806-6231 (FAX)

### 9.2 Field Repairs (In-Warranty Units)

Field repairs involving the replacement of components within a unit are not recommended and may void the warranty and compatibility with any applicable regulatory or agency requirements. If a unit needs repair, contact Charles Industries, Ltd. for replacement or repair instructions, or follow the *Repair Service Procedure* below.

### 9.3 Advanced Replacement Service (In-Warranty Units)

Charles Industries, Ltd. offers an “advanced replacement” service if a replacement unit is required as soon as possible. With this service, the unit will be shipped in the fastest manner consistent with the urgency of the situation. In most cases, there are no charges for in-warranty repairs, except for the transportation charges of the unit and for a testing and handling charge for units returned with no trouble found. Upon receipt of the advanced replacement unit, return the out-of-service unit in the carton in which the replacement was shipped, using the pre-addressed shipping label provided. Call your customer service representative at the telephone number above for more details.

### 9.4 Standard Repair and Replacement Service (Both In-Warranty and Out-Of-Warranty Units)

Charles Industries, Ltd. offers a standard repair or exchange service for units either in- or out-of-warranty. With this service, units may be shipped to Charles Industries for either repair and quality testing or exchanged for a replacement unit, as determined by Charles Industries. Follow the *Repair Service Procedure* below to return units and to secure a repair or replacement. A handling charge applies for equipment returned with no trouble found. To obtain more details of this service and a schedule of prices, contact the CI Service Center at 217-932-5288 (FAX 217-932-2943).

#### *Repair Service Procedure*

1. Prepare, complete, and enclose a purchase order in the box with the equipment to be returned.
2. Include the following information:
  - Company name and address
  - Contact name and phone number
  - Inventory of equipment being shipped
  - Particulars as to the nature of the failure
  - Return shipping address
3. Ship the equipment, purchase order, and above-listed information, transportation prepaid, to the service center address shown below.

CI Service Center  
503 N.E. 15th St, P.O. Box 339  
Casey, IL 62420-2054  
U.S.A.

4. Most repaired or replaced units will be returned within 30 or 45 days, depending on the product type and availability of repair parts. Repaired units are warranted for either 90 days from the date of repair or for the remaining unexpired portion of the original warranty, whichever is longer.

## **10. SPECIFICATIONS**

### **10.1 Physical**

<b>Feature</b>	<b>U.S.</b>	<b>Metric</b>
Height	1.75 inches	4.445 centimeters
Depth	12 inches	30.48 centimeters
Width	17 inches	43.18 centimeters
Weight	8 pounds, 3 ounces	3.71 kilograms
Operating Temperature	-40° to 149° F	-40° to 65° C

### **10.2 Regulatory and Agency Approvals**

- UL/CSA  
Listed under Underwriters Laboratories (UL) Standard 1950. Field repairs may void compliance.
- FCC/DOC  
Verified to meet FCC Part 15 Class A Limit Restrictions for office equipment. Verified to meet FCC Part 68 for network interface connections.

